



# Riverdi STM32 Evaluation Board

## General Description

Rev.1.5

2022-04-07

The STM32 Evaluation Board is developed to evaluate below products:

- [Riverdi intelligent displays with BT817Q\(EVE4\) controller](#)
- [Riverdi High brightness, IPS, displays](#)



## REVISION RECORD

REV NO.	REV DATE	CONTENTS	REMARKS
1.0	2020-08-17	Initial Release	
1.1	2020-11-06	CPU information updated	
1.2	2021-03-09	Pictures updated	
1.3	2021-03-31	Document adjusted into standard template	
1.4	2021-10-27	Updating new template	
		Specify the scope of applied product:	
1.5	2022-04-07	Only support evaluating <a href="#">Riverdi EVE4 (BT817Q) Series</a> and <a href="#">Riverdi High Brightness, IPS Series</a> .	



## CONTENTS

REVISION RECORD.....	2
CONTENTS.....	3
1. INTRODUCTION.....	4
2. SOLUTION TO EVALUATE RIVERDI DISPLAYS.....	4
3. EXTENSION DON ADDON BOARD .....	5
4. RESOURCES CAN MAKE A REAL IMPACT .....	6
5. READY-TO-USE SOFTWARE.....	7
6. SUMMARY .....	8
7. LEGAL INFORMATION.....	9

## 1. INTRODUCTION

The aim of this document is to present the reader with the general idea behind the device and the environment in which Riverdi STM32 Evaluation Board works. The detailed manual for engineers using it is in a different document titled 'Riverdi STM32 Evaluation Board User Manual'.

## 2. SOLUTION TO EVALUATE RIVERDI DISPLAYS

Riverdi STM32 Evaluation Board is an evaluation/development board intended for development and use of applications on a wide range of Riverdi displays. It supports [Riverdi intelligent displays with BT817Q \(EVE4\)](#) for displays from 3.5" through 10.1" and [Riverdi High Brightness, IPS displays with RGB, LVDS and DSI interfaces](#) (the two last types must have additional serializer) in combination with different types of touch panels.

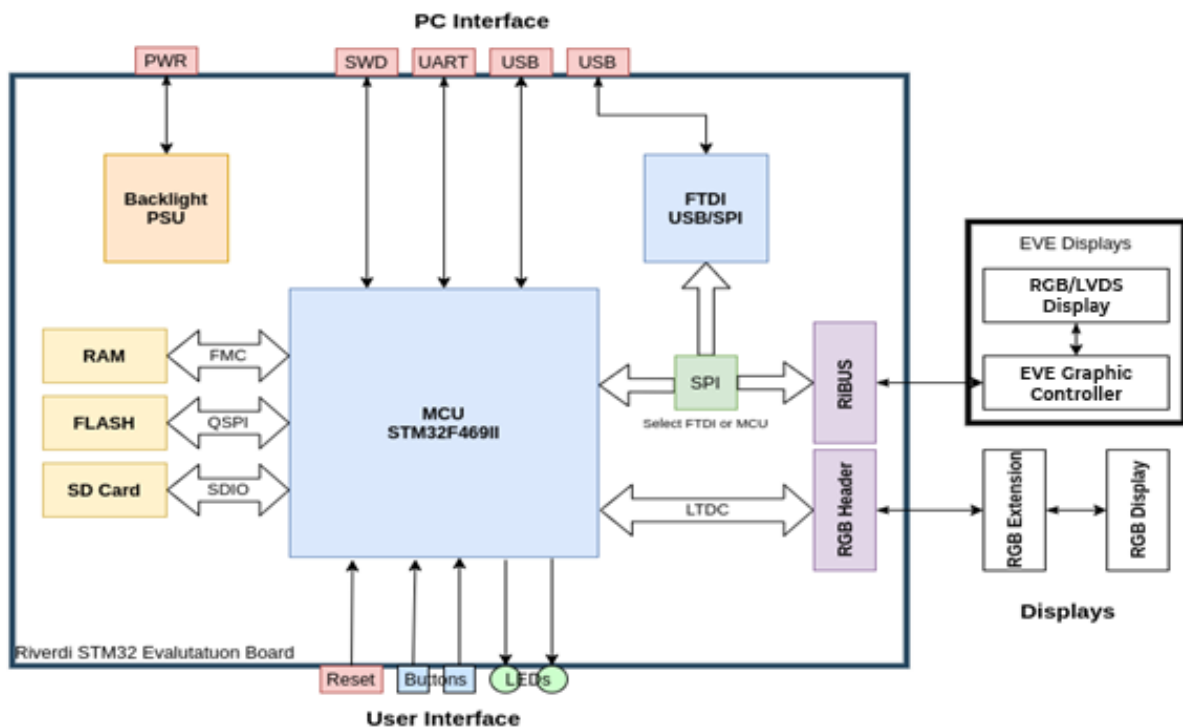

The Riverdi STM32 Evaluation Board contains all necessary components for successful development of graphic applications, including:

- USB Interface,
- Micro SD Card interface,
- 2 user programmable LEDs,
- 2 user programmable buttons,
- Debug UART interface.

While STM32 controller is powered by a USB interface, the displays can be supplied either from the same DC source or from an independent DC power source.



Regarding the application – it can be developed as an embedded application running on built-in STM32 TFT controller, or as an application running on another system using built-in Bridgetek/FTDI libraries to communicate with the target EVE graphic engine via the SPI interface and the RiBUS connector.

### 3. EXTENSION DON ADDON BOARD

While the evaluation board itself contains all key components plus the RiBUS interface to EVE4 displays – the RGB extension header brings the interface to most of Riverdi High Brightness, IPS displays with RGB interface.

The evaluation board can use either RiBUS to drive the display with BT817Q (EVE4) graphics controller or the RGB extension. Don Addon Board, apart from delivering signals to the display, plays a role of a physical carrier to the whole module. Therefore, Don Addon Boards must be customized to the displays they are serving.

Because of STM32F469II resolution limitation, it is currently possible to connect [Riverdi High Brightness, IPS 10.1" displays](#) only via RiBUS - so they must be models with BT817Q controller.

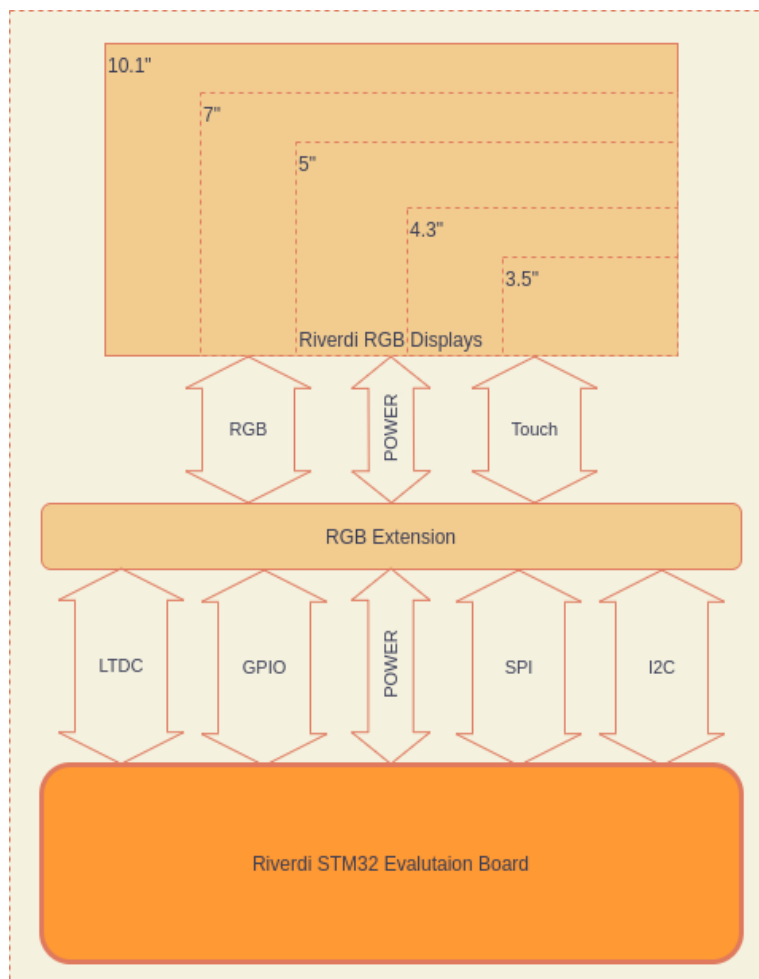

**Note:** So far, Riverdi High Brightness, IPS 10.1" displays are available with LVDS interface, Riverdi High Brightness, IPS, 7.0" displays with either LVDS, RGB, MIPI interfaces, and all the rest Riverdi High Brightness, IPS, 3.5", 4.3" and 5.0" are with RGB interface as standard.



## 4. RESOURCES CAN MAKE A REAL IMPACT

Compared to EVE displays, where most of the graphic and UI operations are handled by a graphics processor, STM32 carries out the same operations when driving the RGB displays. In such conditions, the high processing power of the STM32F469II processor becomes apparent and comes to action.

Regarding the embedded systems and applications that control the display, the resources on the board can be the key factor to success. Compared to usual embedded systems in which a microcontroller is used to do less complex operations, e.g. sensor reading or motor control – and where Cortex M0 processor is more than enough to handle all tasks – in case of systems that primarily control the display, the amount of necessary resources grows rapidly. According to EE Times, now only 14% of the graphic files are handled by 32-bit systems. This fact puts Riverdi in the group of technology leaders.

The key requirements for such systems are:

- Processing power,
- RAM memory,
- Non-volatile memory.

Processing power is necessary to allow a smooth operation of a display as well as perform any required operations happening in the background. RAM memory should be big enough to store at least the complete frame buffer for higher resolution and color depth screens. Finally, non-volatile memory is necessary to store all objects used in a graphics application like fonts or icons. Considering all above facts, Riverdi STM32 Evaluation Board is designed carefully to meet all the key requirements.

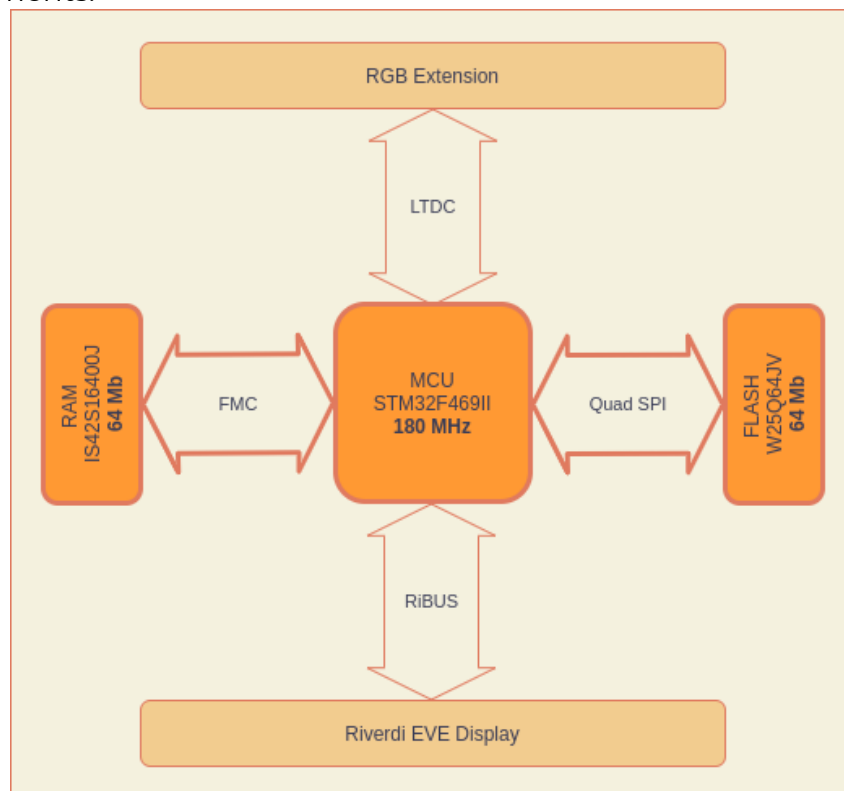



The key component, the STM32F469II Cortex M4 microcontroller, is running with clock frequency up to 180MHz and carry 2MB of the non-volatile and 384KB of internal RAM. Alongside the microcontroller, the evaluation board contains additional IS42S16400J 64Mb external RAM connected through 32-bit data bus and W25Q64JV 64Mb external Flash memory, connected through Quad SPI interface.

Riverdi STM32 Evaluation Board shows the maximum potential when STM32F469II micro-controller's internal LCD TFT parallel interface is used alongside DMA2D graphical hardware accelerator.

## 5. READY-TO-USE SOFTWARE

Riverdi has prepared official, ready-to-use examples for the STM32 Evaluation Board as a means of help for hardware engineers. No matter which one of the two available display options is preferred (Riverdi EVE4 Series or Riverdi High Brightness, IPS Series), open-source libraries and example applications can be downloaded, including drivers for all peripherals mounted on the board (TSC2046, W25Q64JV, ILI2132A etc.). Using the examples provided means hardware engineers can avoid the stressful situation of having to find the root cause of the module not functioning and not having assistance. In order to function correctly, Riverdi STM32 Evaluation Board must be unpacked, brought to room temperature and have the examples loaded.

All example applications are developed in a way that can be used as a starting point for the end customer's own project with an emphasis on reusable, clean, well-documented and easily understandable code. The code examples are developed using well-known toolchains and IDE provided by ST, including: STCubeIDE, STMCubeMX and SystemWorkbench for STM32.

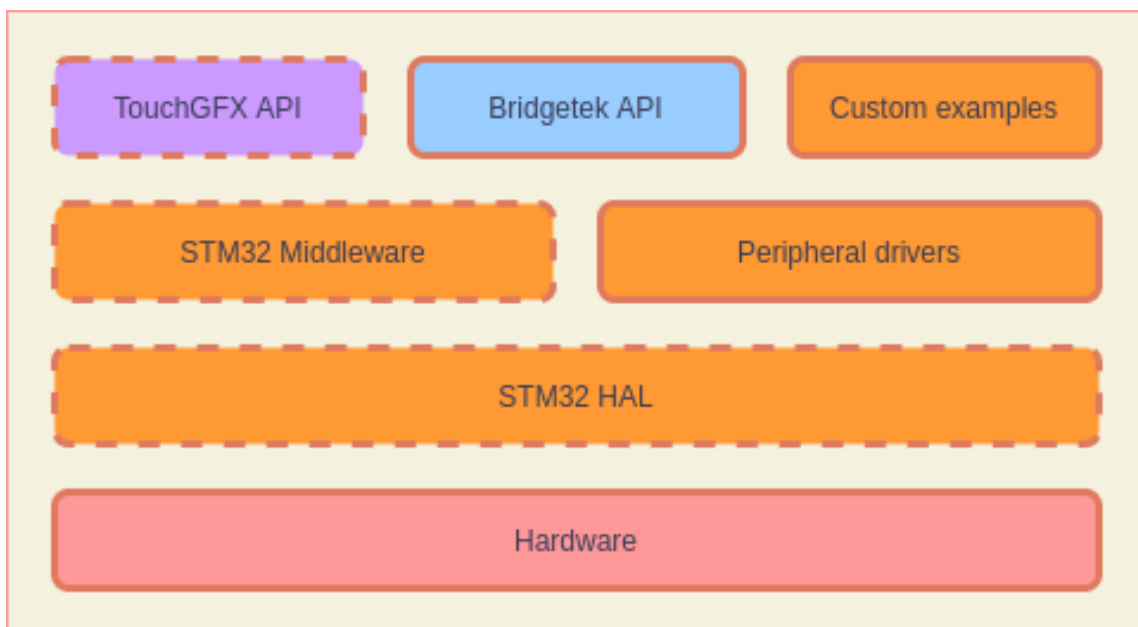



Regarding the GUI development and depending on the type of the display the end customer uses, there are also a few free tools available that simplify the development work. In case of RiBUS and EVE displays, there is EVE Toolchain with a few different PC applications for this purpose.

Compared to Bridgetek, ST provides a well-known TouchGFX code generator that creates a high-level API which can be connected to a previously generated lower-level code by CubeMX or CubeIDE. Riverdi also provides the External Flash loader necessary to download the image data directly to the QuadSPI Flash during the programming process.

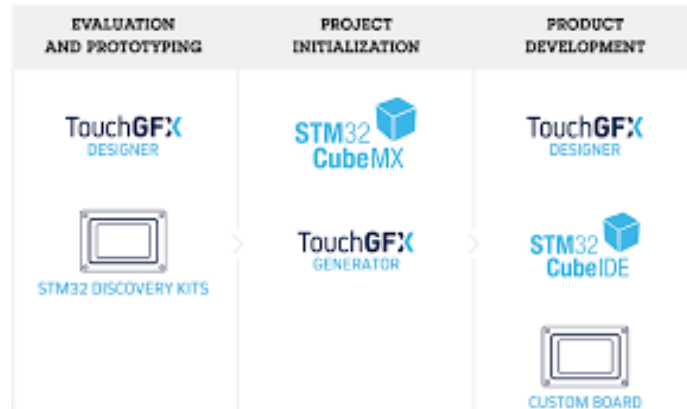

It is also important to mention that ST provides plenty of different, ready-to-use templates that can be integrated easily to Riverdi STM32 Evaluation Board.

## 6. SUMMARY

If this document has made you interested in knowing more about Riverdi products, please visit [Riverdi](http://www.riverdi.com) website: